

Owiert kołnierza
PN 10
PN-EN 1092-1

TEHACO®

Nr karty
3.9.2.

Długość zabudowy G
wg normy zakładowej
ZN 98/039

ZASUWA NOŻOWA typ DKG

WYMIARY

Średnice nominalne
DN 80 – DN 400

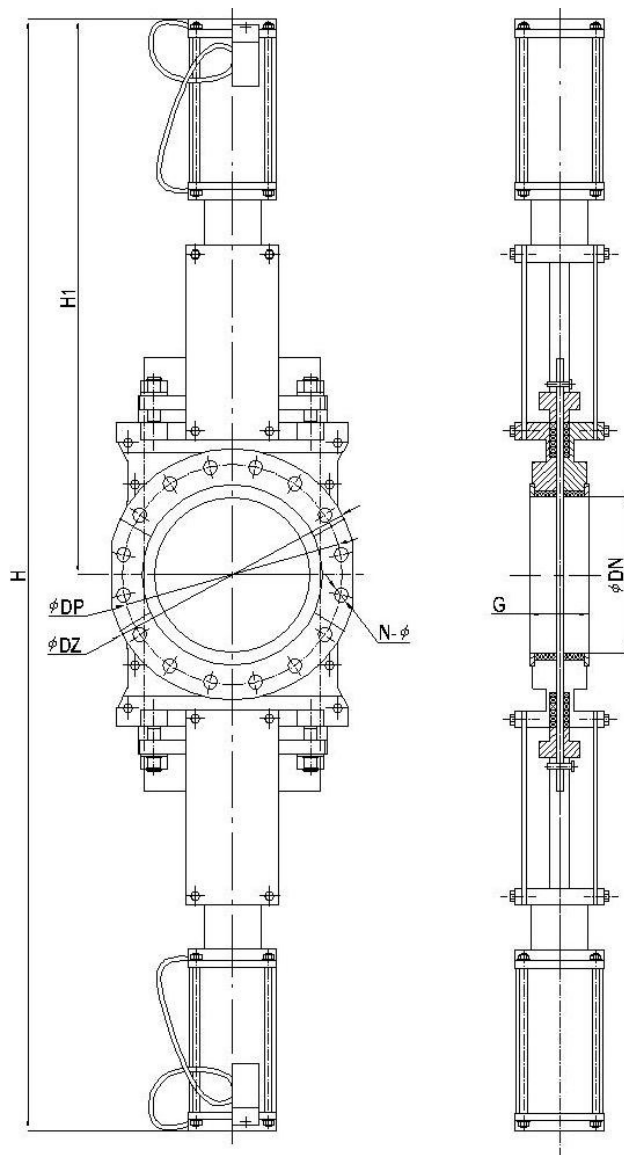

Rys. Zasuwa nożowa typ DKG.

Tabela wymiarowa.

DN	Pr [MPa]	G [mm]	H [mm]	H1 [mm]	ØDZ [mm]	ØDP [mm]	N-Ø	Ø Cylindra x skok [mm]	M [kg]
80	1.0	66	860	430	200	160	4-M16	100 x 45	46.0
100	1.0	66	900	450	220	180	8-M16	100 x 52	49.0
125	1.0	66	940	470	250	210	8-M16	125 x 65	58.0
150	1.0	74	1080	540	285	240	8-M20	125 x 78	70.0
200	0.6	74	1340	670	340	295	8-M20	160 x 102	85.0
250	0.6	80	1580	790	395	355	12-M20	200 x 128	95.0
300	0.6	80	1780	890	445	400	12-M20	200 x 152	170.0
350	0.3	96	1190	995	505	460	16-M20	250 x 178	270.0
400	0.3	102	2200	1100	565	515	16-M24	250 x 204	350.0

TEHACO – edycja lipiec 2008
Producent zastrzega sobie prawo wprowadzania zmian konstrukcyjnych